



2024 UccMS Rules

Rev 1

Last Revision Date 11/15/2023

National Director – Todd Padgett – (765) 631-9212

Mid Atlantic Director – Erin Cusack - (508) 733-2154

Midwest Region Director - Ryan Robey – (740) 312-3046

South Region Director – Jody Brannon - (931) 205-7100

The rules and/or regulations set forth herein are designed to provide for the orderly conduct of racing events and to establish minimum acceptable requirements for such events. These rules shall govern the condition of all events, and by participating in these events, all participants are deemed to have complied with these rules. No expressed or implied warranty of safety shall result from publications of or compliance with these rules and/or regulations. They are intended as a guide for the conduct of the sport and are in no way a guarantee against injury or death to a participant, spectator or official. The director(s)/official(s) shall be empowered to permit reasonable and appropriate deviation from any of the specifications herein or impose any further restrictions that in his opinion do not alter the minimum acceptable requirements. No expressed or implied warranty of safety shall result from such alteration of specifications. Any interpretation or deviation of these rules is left to the discretion of the director(s)/officials and their decisions are final.

Contents

| | | |
|--------|--|----|
| 1. | GENERAL RULES | 3 |
| 2. | MODIFIED LITE (UMP/DIRT) & CLASSIC MODIFIED (DWARF CAR) SPECIFICATIONS | 3 |
| 3. | BODY SPECIFICATIONS | 4 |
| 3.1. | Modified Lite Body Specifications “All Styles” | 4 |
| 3.2. | Classic Modifieds “Dwarf Car” Body Specifications..... | 4 |
| 3.3. | UMP/DIRT BODY SPECIFICATIONS (DIRT FIGURE 2)(UMP FIGURE 6) | 5 |
| 3.3.1 | Hood and Nose Section (DIRT FIGURE 3)(UMP FIGURE 7)..... | 5 |
| 3.3.2 | Roof Panel (DIRT FIGURE 5)(UMP FIGURE 9)..... | 5 |
| 3.3.3 | SIDE WINDOW (MANDATORY NO TOLERANCE) (DIRT FIGURE 4)(UMP FIGURE 8) | 5 |
| 3.3.4 | REAR UPPER QUARTER PANEL/ SAIL PANEL (UMP/DIRT FIGURE 13) | 6 |
| 3.3.5 | REAR DECK (DIRT FIGURE 10)(UMP FIGURE 11) | 6 |
| 3.3.6 | REAR SPOILER (DIRT FIGURE 10)(UMP FIGURE 11)..... | 6 |
| 3.3.7 | REAR FRAME AREA..... | 6 |
| 3.4. | UMP SPECIFICATIONS ONLY | 6 |
| 3.5. | DIRT CAR SPECIFICATIONS ONLY..... | 7 |
| 4. | WEIGHT | 11 |
| 5. | BUMPER DIMENSIONS | 11 |
| 6. | FIREWALL | 11 |
| 7. | WINDSHIELD..... | 11 |
| 8. | NERF BARS..... | 11 |
| 9. | SEAT | 11 |
| 10. | NUMBERS, GRAPHICS, AND TRANSPONDERS | 12 |
| 11. | BATTERY, and FUEL SYSTEM | 12 |
| 12. | DRIVE TRAIN..... | 12 |
| 13. | FRAME and ROLL CAGE (FIGURE 14) | 12 |
| 14. | SUSPENSION..... | 13 |
| 14.10. | REAR TRAILING ARMS/RADIUS SPECIFICATIONS/3 RD LINK/PANHARD BAR..... | 14 |
| 14.11. | SHOCKS/SPRINGS..... | 14 |
| 14.12. | SHOCK CLAIM POLICY (\$150 per Shock)..... | 14 |
| 14.18. | STEERING | 14 |
| 14.19. | BRAKES | 14 |
| 15. | WHEELS AND TIRES | 15 |
| 16. | SAFETY EQUIPMENT..... | 15 |
| 17. | ENGINE SPECIFICATIONS STOCK/SPEC ONLY | 15 |
| 17.1. | ALLOWABLE ENGINE PACKAGES | 15 |
| 17.2. | Engine Mounting..... | 15 |
| 17.3. | GENERAL ENGINE RULES..... | 16 |
| 17.4. | CAMS..... | 17 |
| 17.5. | OIL SYSTEM..... | 17 |
| 17.6. | FUEL SYSTEM | 17 |
| 17.7. | IGNITION SYSTEM | 17 |

| | |
|---|----|
| 17.8. FUEL | 18 |
| 17.9. ENGINE TECH PROCEDURES | 18 |
| 18. MISCELLANEOUS RULES | 18 |
| 19. GENERAL REGULATIONS..... | 18 |
| 20. GENERAL GUIDELINES FOR CONDUCT PERTAINING TO RULES INFRACTIONS..... | 20 |
| 21. RACERS' CODE OF CONDUCT | 20 |
| 22. MEDIA RELATIONS | 22 |
| 23. TECHNICAL INSPECTIONS | 22 |
| 24. FORMS OF DISCIPLINE..... | 23 |
| 25. PROTEST..... | 24 |

Any car specifications not covered in these rules/guidelines' specs are subject to UccMS officials' interpretation. Any significant performance advantage will be addressed on an individual basis. UccMS officials' reserve the right to determine what constitutes a performance advantage.

1. GENERAL RULES

- 1.1. United cc Modified Series race rules shall apply to all sanction events. All vehicles are subject to inspection at any time.
- 1.2. Approval of a vehicle by the inspector shall mean that the vehicle is approved for participation in a competitive event and shall not be construed in any way to mean that the inspected vehicle is guaranteed mechanically sound. Be it further declared that the inspector should not be liable, nor the sanctioning body, for any mechanical failure, loses, injury or death.

2. Modified Lite (UMP/DIRT) & Classic Modified (Dwarf Car)

Specifications

- 1.1. There are three styles of body specification known as "UMP", "DIRT", and "Dwarf Car" and will all be referred to as one group "Modified Lite" unless specified otherwise.
- 1.2. All Chassis specifications are the same for all body styles.
- 1.3. All measurements may be taken with or without the driver and/or with/without fuel.
- 1.4. Tolerance permitted on all body dimensions is a maximum of +/- (plus or minus) ½" -inch (one half inch) This is a tolerance, not a dimension that is to be added to body dimensions.
- 1.5. The intent of these specifications is to follow the bodyline and design of an existing UMP/DIRT or Classic Modified racecar.
- 1.6. Body must be 5/8 scale, stock appearing.
- 1.7. Maximum outside tire width of 60", and maximum wheelbase of 73" plus or minus 1". When measuring wheelbase front tire must be in line with rear tire.
- 1.8. Cars must pass freely through a hoop of 60 ½" wide by 52 ½" high. (NOTE: The hoop already has tolerance built in so if any two parts of the car touches hoop at the same time(width) or roof at any time it is illegal) Refer to Figure # 1
- 1.9. No car taller than 52" from highest point to ground.
- 1.10. 132" Maximum total length, bumper to bumper, measured from outside to outside of bumper.

- 1.11. Kick outs or side nerf bars must be mounted to two or three points and run full length between tires. May not touch while rolling through during tech.

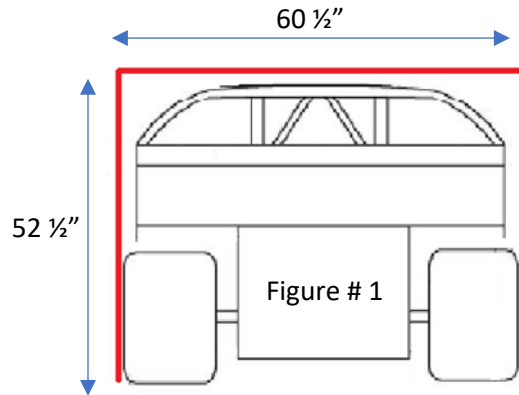

3. Body Specifications

3.1. Modified Lite Body Specifications "All Styles"

- 3.1.A. Body height maximum of 46" from bottom edge to top (including frame rail, and/or but not limited to body plastics)
- 3.1.B. Maximum body width of 55" at decking and/or top of door panel.
- 3.1.C. Roof hatch entry allowed and recommended.
- 3.1.D. Fasteners on hood trunk or panels must be positive locking type.
- 3.1.E. Skirt may be used a bottom of doors are rear quarter panel. May only be installed in a vertical manner. Skirting is not included in body dimension measurements.

3.2. CLASSIC MODIFIEDS "DWARF CAR" BODY SPECIFICATIONS

- 3.2.A 5/8 scale 1928-1948 American made production, two door vintage coupe, sedan, sedan delivery, wagon, or pick-up truck only.
- 3.2.B Must have a grill, shell or simulated open nose matching original body style.
- 3.2.C Doors, windows, and cowlings must retain stock appearance.
- 3.2.D Hood louvers allowed for cooling but must maintain stock contour.
- 3.2.E Engine compartment must conform to scale and match contour of body. Hole may be cut for breather clearance only. Ram air induction system prohibited.
- 3.2.F Trunk must be fully contour to original body line. Access opening allowed as long as it does not detour original bodyline. Louvers allowed; holes prohibited.
- 3.2.G No Fenders, No Wings, No Spoilers, no lips, of any kind.
- 3.2.H Body will be metal composition, with a minimum of 26-gauge steel or .040" aluminum. All exposed edges must be folded and/or trimmed over.
- 3.2.I No open top cars (roadsters, convertible). Only closed top meaning hardtop.
- 3.2.J Body Contour must follow frame and roll cage. Roof hatch recommended.
- 3.2.K Drivers' door must be operational and equipped with secure latch.

3.3. UMP/DIRT BODY SPECIFICATIONS (DIRT FIGURE 2)(UMP FIGURE 6)

- 3.2.A** 86" Max – Door and rear quarter combined length.
- 3.2.B** 30" min 38" max -side height of rear quarter panel from ground. 30" Max Height of quarter panel.
- 3.2.C** Rear quarter distance from center of rear 20" min 32" max
- 3.2.D** Cockpit cover with a max lip of ½" will be permitted providing on/off cut off switch reachable from outside the car by safety personal.
- 3.2.E** Deck lid height from ground 30" min 36" max.
- 3.2.F** Body must be centered on chassis.
- 3.2.G** If a windshield is used it must be flat.
- 3.2.H** All body dimensions will be tech'd +/- ½" unless otherwise specified.
- 3.2.I** Body will be metal composition, with a minimum of 26-gauge steel or .040" aluminum. All exposed edges must me folded and/or trimmed over. STAKT PRODUCT will be the only Allowable Composite Body Parts Manufacture Allowed for use.

3.3.1 HOOD AND NOSE SECTION (DIRT FIGURE 3)(UMP FIGURE 7)

- 3.3.1.A** 20" min 29" max – hood height excluding breather protectors (bottom of frame rail to top of hood).
- 3.3.1.B** Nose is defined as 8" in front of lower ball joints. Anything behind that is defined as the hood.
- 3.3.1.C** Rear of hood becomes part of windshield area rules.
- 3.3.1.D** No part of nose section (in front of spindle centerline) may be wider than a maximum of 24". "DIRT" design must resemble approved "DIRT" car nose.
- 3.3.1.E** Maximum of 1 ½" side fins allowed on aluminum nose, must stop by end of nose, no fins on hood allowed.
- 3.3.1.F** Cooling Holes allowed.

3.3.2 ROOF PANEL (DIRT FIGURE 5)(UMP FIGURE 9)

- 3.3.2.A** 40" min 48: max – length of roof panel. 36" min 42" max – width of roof.
- 3.3.2.B** No part of roof panel may have more than 14 degrees of angle rake. No deflector of any type on upper sides or rear of roof panel. Roof entrance hatch optional.
- 3.3.2.C** Maximum ¾" ridge down sides of roof.
- 3.3.2.D** Maximum ¾" rear roof stiffener (must face down).
- 3.3.2.E** Maximum 1 ½" rolled down rock guard allowed on roof front.

3.3.3 SIDE WINDOW (MANDATORY NO TOLERANCE) (DIRT FIGURE 4)(UMP FIGURE 8)

- 3.3.3.A** Driver and passenger side window must have 18" minimum opening length.
- 3.3.3.B** Driver and passenger side window must be a minimum of 10" height front to rear.

3.3.4 REAR UPPER QUARTER PANEL/ SAIL PANEL (UMP/DIRT FIGURE 13)

- 3.3.4.A 20" min 38" max rear upper side panel may be plexiglass or be open.
- 3.3.4.B Side panel may be no higher than the imaginary line from the rear edge of roof panel to 3" above the top edge of the rear quarter panel.
- 3.3.4.C Both side panels will be a mirror image.
- 3.3.4.D Side panel will not have more than a 3" bow from inside to outside of panel.

3.3.5 REAR DECK (DIRT FIGURE 10)(UMP FIGURE 11)

- 3.3.4.A 46" min 55" max – width of rear shelf and body panels.
- 3.3.4.B Rear shelf may have no more than 5 degrees rake and may not be concave or convex in design. (Flat deck only)

3.3.6 REAR SPOILER (DIRT FIGURE 10)(UMP FIGURE 11)

- 3.3.6.A One Piece, aluminum/Lexan spoiler with a maximum height of 4" from the rear deck will be permitted.
- 3.3.6.B The rear spoiler must be non-adjustable from the cockpit and/or during racing conditions. Hinges, adjuster(s), slides and/or any other adjusting type devices will be permitted.
- 3.3.6.C A break and/or bend on the top of the aluminum/Lexan spoiler will be permitted for reinforcement.
- 3.3.6.D The overall height of the spoiler when measured from the ground must not exceed 40".
- 3.3.6.E No vertical supports for the purpose of fastening the spoiler to the rear deck will be permitted.

3.3.7 REAR FRAME AREA

- 3.3.7.A The rear frame area from the rear shelf/deck downward may have an optional enclosed panel.
- 3.3.7.B Louvers and holes permitted.

3.4. UMP SPECIFICATIONS ONLY

- 3.3.1 Approved plastic nose pieces allowed. Plastic nose pieces must be mounted in an approved manner and can extend no further back than the front hood.
- 3.3.2 Hood may taper out towards the door panels behind the centerline of the spindles.
- 3.3.3 Decking must extend from front of doors to rear of quarter panel, not to exceed 5 degrees max rake and may not be concave or convex in any way. (Flat deck only)
- 3.3.4 Hood area must taper at a minimum, back to hood measurements by centerline of spindles. 3.3.1.
- 3.3.5 Side pods are not permitted under UMP style.

3.5. DIRT CAR SPECIFICATIONS ONLY

3.3.1 36" min 56" max length of right-side pod area with max of 30 degrees. Left side pod may be altered for driver access.

3.3.2 Side pod(s) may not extend rearward past centerline of rear axle.



DIRT Body Style

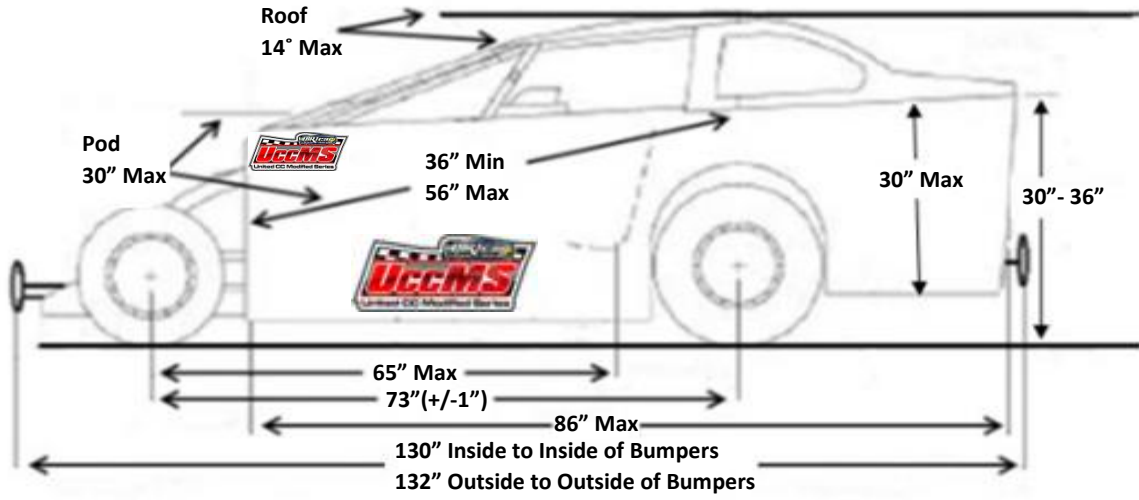

DIRT BODY FIGURE 2

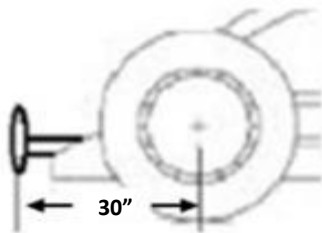

DIRT FIGURE 3

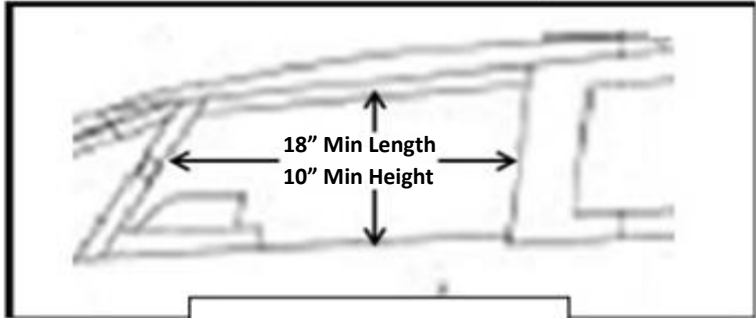

DIRT FIGURE 4

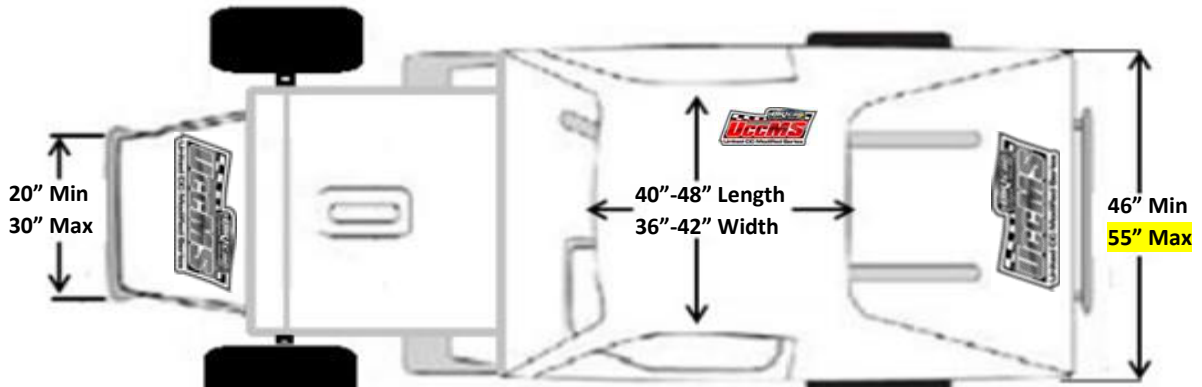

Dirt Figure 5



UMP Body Style

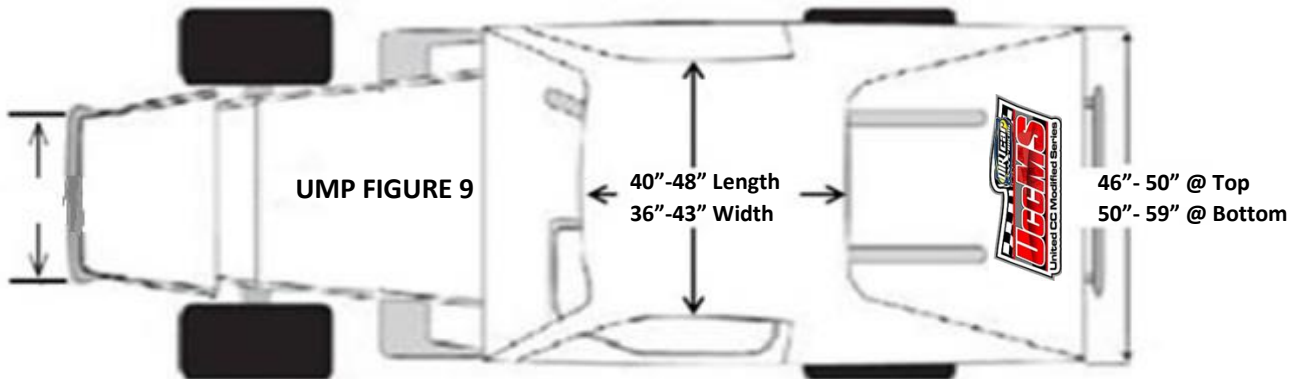
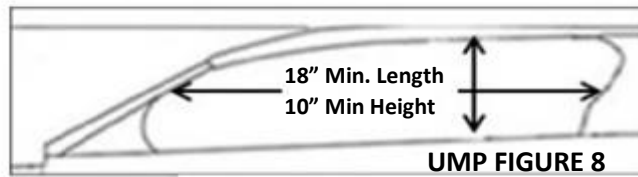
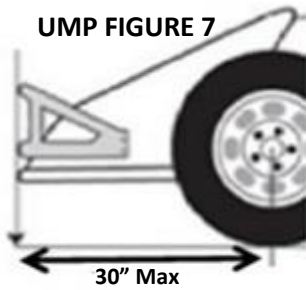
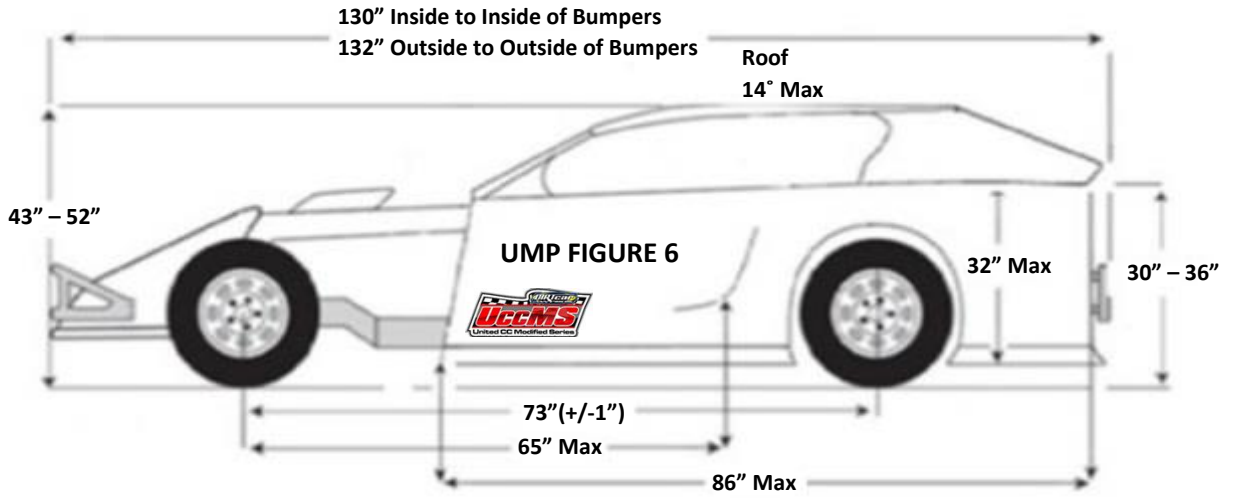

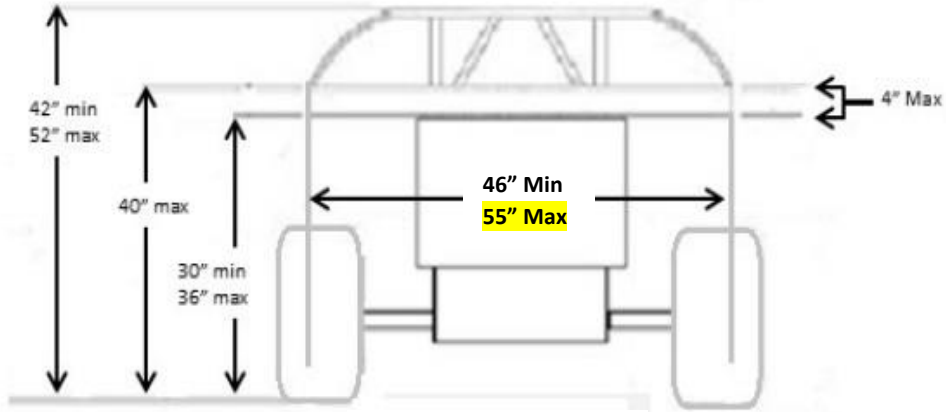

DIRT FIGURE 10

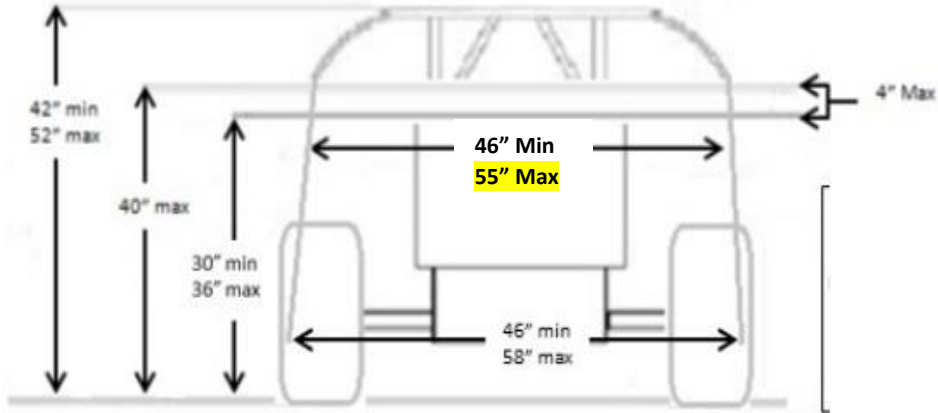

UMP FIGURE 11

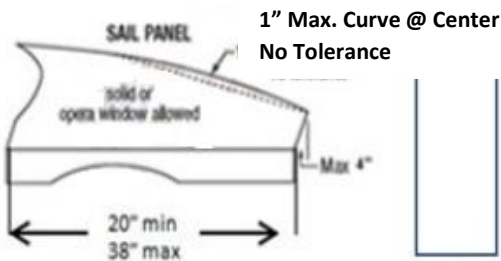

UMP

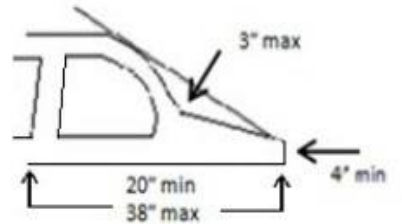

DIRT

UMP/DIRT FIGURE

4. WEIGHT

- 4.1. All cars following the UccMS UMP/DIRT program must weigh a minimum of 1325 lbs. with driver after race.
- 4.2. No weight outside of car body, including but not limited to nerf bars.
- 4.3. No Weight above the deck.
- 4.4. Hood Will be clearly marked minimum weight as outlined in rules.
- 4.5. The weight program will be monitored for parity and competitiveness and may be changed at the discretion of the UccMS Series.
- 4.6. Weight adding to rear axle tubes will not be permitted.
- 4.7. Pro Classic Dwarf Cars 1000cc at 1325lbs
- 4.8. Classic Dwarf Cars 750cc at 1240lbs
- 4.9. Charger Dwarf Cars 750cc at 1240lbs
- 4.10. JR. Sportsman Dwarf bodies 750cc at 1100lbs

5. BUMPER DIMENSIONS

- 5.1. Front maximum width 30". Bumper height 6" to 8", with 2-bar loop. Ground to top of bumper 12" minimum 18" maximum. Bumper may not extend more than 30" forward of front spindle centerline.
- 5.2. Rear maximum width 56" with 3 vertical bars. Bumper height 6" to 8" with 2 bar configurations. Ground to top of bumper: 12" min. 18" max. May not extend more than 10" behind rear body panels.
- 5.3. Bumpers must be hollow with max wall thickness of 0.125".
- 5.4. Front bumper minimum width will be 20".

6. FIREWALL

- 6.1. Firewall must be metal and must completely separate engine compartment from cockpit. Engine protruding into cockpit must be enclosed.

7. WINDSHIELD

- 7.1. Windshield must be Lexan, wire mesh, or protection bars. No Glass. All other cockpit areas must remain open with the exception of optional mesh window net. Deflectors may be used in front of driver. May be no wider than the roll bar area.

8. NERF BARS

- 8.1. Full length nerf bars between front and rear bars mandatory. Max. outside diameter of 1 ¼" and 0.125" maximum thickness, must be hollow. May not extend outward of tread width at front and may extend no more than 1" at rear(not tolerance).

9. SEAT

- 9.1. Seat must be high-backed aluminum, racing type. All car cars will have a permanent bar located behind top of seat at driver shoulder level.

- 9.2. Full Containment Style Seat Recommend for Adults, Required for Jr. Series.

10. NUMBERS, GRAPHICS, AND TRANSPONDERS

- 10.1. Car number must be displayed on both side door Panels and roof.
10.2. Individual single digit numbers height must be a min. of 24" in height and 8" in width.
10.3. Transponder **MUST** be mounted on LR axle tube.

11. BATTERY, and FUEL SYSTEM

- 11.1. Battery and fuel pump must be mounted outside of driver compartment. Battery must be secure and held with non-rubber strap. Electric fuel pump allowed.
11.2. Fuel cell mandatory, max. 5 gallons, located in rear frame area.
11.3. High pressure fuel line to be used.
11.4. A direct manual cut-off switch mandatory located to right of driver seated in car easily accessible and visible by track personal. The cut-off switch will be clearly marked and labeled.

12. DRIVE TRAIN

- 12.1. Must use steel drive shaft from transmission to rear end. Minimum 2.50" x 0.83" or 2" x 0.120"
12.2. Quick change rear end allowed with steel tubes only.
12.3. Rear must be locked and have solid spool.
12.4. Steel axle(s), or solid one-piece aluminum axle type allowed. No titanium.

13. FRAME and ROLL CAGE (FIGURE 14)

- 13.1. Drive shaft tunnel must have a min. of 2 (3 recommended) hoops or bars between firewall and seat back. Must be fabricated of minimum 0.1875" x 1 1/2" steel bar and/or 1" x 0.095 steel tube.
13.2. Mainframe rails consist of the length between the front lower a-arms cross member and the rear main roll bar upright
3.3.1 Mainframe rail members will be a min. of 1" x .120" wall rectangular steel tubing or 1 1/2" DOM 0.095" material non-seamed only.
3.3.2 Mainframe rails will have a minimum of 3 cross members between firewall and back of seat, fabricated of same materials as mainframe rails.
3.3.3 Cross bracing in floor under drive highly recommended.
3.3.4 Mainframe may taper inward forward of driver area.
13.2.4.A Front engine area frame width must be a min. 24", max. 24" outside dimension.
3.3.5. Left and right mainframe rails must mirror +/- 1/2".
13.3. No aluminum allowed in cage or frame construction.
13.4. Rear frame rails at roll bar must be min 30" max 34" outside dimension.
13.4.1. Rear roll bar must meet same dimensions as the frame rail it is mounted to.
13.5. Roll cage must be DOM steal min 1.25" x 0.083" (0.095" highly recommended).
13.5.1. Cross or diagonal bracing strongly recommended in hoop over drives head, bars to be welded in place as part of roll cage. Min. size of 1" x 0.083".
13.5.2. Cars should have full doorframe and a minimum of 2 horizontal cross bars. Min size of 1" x 0.083", with a min of 2 vertical cage bars.

- 13.5.3.** It is required to have a steel bar from doorpost to doorpost, under dash minimum size of 1" x 0.083".
- 13.5.4.** No downtube frame cars allowed. Any bars going from cowl area to snout must remain below the upper line of hood.

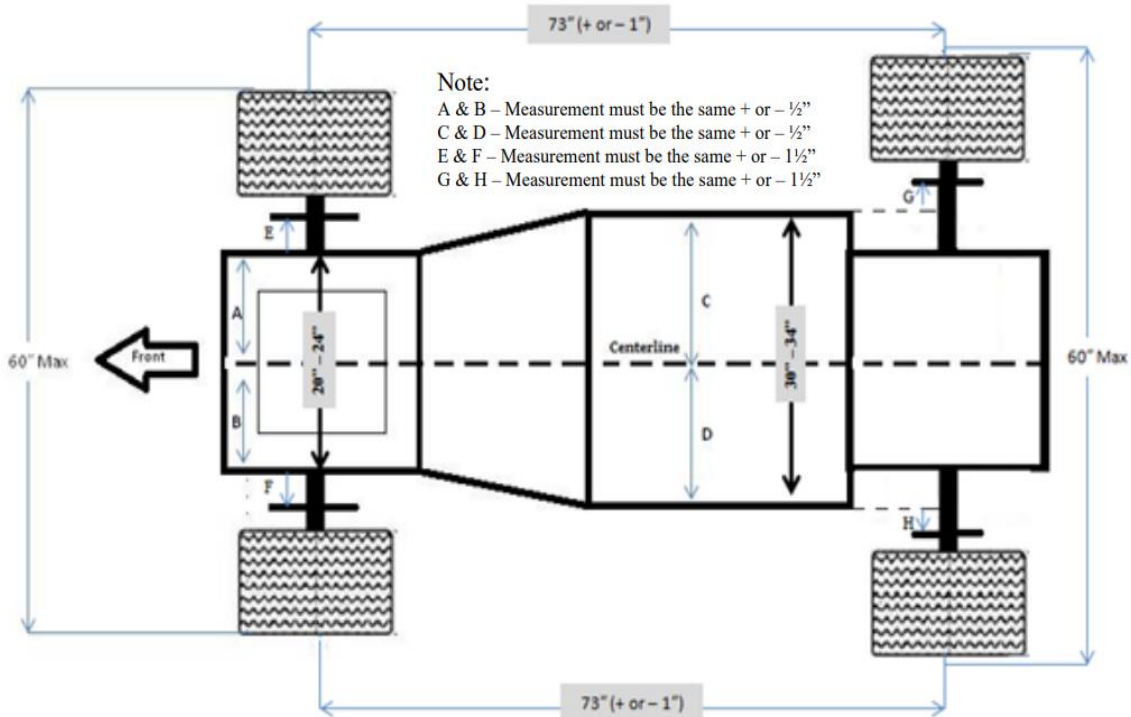

Figure 14

14. Suspension

- 14.1.** Front suspension must not extend rearward past the most forward panel of the firewall.
- 14.2.** Wheel offsets are allowed.
- 14.3.** Hub offsets are NOT allowed. Hubs front and rear must be within 1/2" distance from mainframe rail on either side of car, measured from the center of rotor to vertical plane of frame rail.
- 14.4.** No driver shall have the ability to adjust suspension from inside of car.
- 14.5.** Straight front axles are not permitted.
- 14.6.** No birdcage type rear linkage, birdcages must be solid mounted.
- 14.7.** No Anti-roll (sway) bars permitted front or rear.
- 14.8.** No torsion bar suspension system of any type allowed. No lift bars.
- 14.9.** No cant-a-lever or can-a-lever type device will be permitted in or on any area of the race car.

14.10. REAR TRAILING ARMS/RADIUS SPECIFICATIONS/3RD LINK/PANHARD BAR.

- 14.10.1.** Arms may have a max. length of 30”.
- 14.10.2.** Torque-absorbing devices are permitted, by means of rubber biscuit style only (NO SPRINGS).
- 14.10.3.** 3rd Link may have spring or rubber type absorbing device (NO SHOCK). And may be Forward or Rear Facing.
- 14.10.4.** Max, of 3 radius rods (trailing arms) or 3 link suspension.
- 14.10.5.** Both Trailing Arms Must be forward from rear end. With the exception of Panhard bar.

14.11. SHOCKS/SPRINGS

- 14.11.1.** NO leaf spring(s).
- 14.11.2.** Coil-over shock(s)/Spring(s) are the only allowable means of supporting the chassis. One shock and one spring per wheel only. Shock and spring must remain as one unit.
- 14.11.3.** No stacked/take up/helper spring allowed.
- 14.11.4.** Shocks must be of all steel construction, non-adjustable type.
 - 14.11.4.1.** No Schrader valves allowed.
- 14.11.5.** Drop limiter allowed of any construction, it may only contain one spring/rubber if used. NO AIR DEVICES.

14.12. Shock Claim Policy (\$150 per Shock)

- 14.13.** Shock claims are only allowed for Top 5 drivers at the end of a race.
- 14.14.** Should the event be multiple consecutive days at same venue, the claimed shocks will be marked and surrendered on last day of event. Officials have the right to impound overnight.
- 14.15.** Claim fee must be paid in full by cash to the United cc Modified Series Race Director or his designated representative within 10 minutes after the event.
- 14.16.** If one claims another’s shock, an additional 10 mins. will be added to counterclaim.
- 14.17.** Not reporting to tech, refusing a claim/counterclaim, or intentionally damaging/altering will DQ you for night, including loss of points and winnings.

14.18. STEERING

- 14.18.1.** All steering components must have safety fasteners, such as but not limited to cotter pin(s), locking nut(s), double nut(s), set screw(s), jam nut(s).
- 14.18.2.** Manufactured quick-release steering wheel hubs mandatory.
- 14.18.3.** Rack and pinion steering is mandatory.

14.19. BRAKES

- 14.19.1.** All four wheels must have working calipers and rotors.

- 14.19.2.** Adjustable brake bias and wheel shut-off allowed, in cockpit.
- 14.19.3.** Steel rotors only.
- 14.19.4.** Steel OEM calipers or aluminum calipers only.
- 14.19.5.** Drilling of rotors permitted.
- 14.19.6.** Competition type master cylinders allowed.

15. WHEELS AND TIRES

- 15.1.** Steel wheels only, minimum wall thickness 0.095", 13" only, wheel width max. 8".
- 15.2.** Bead lock rims optional.
- 15.3.** The official tire for UccMS is the American Racer 22.5/8.0-13 with allowable compounds of SD44, SD48, SD57.
- 15.4.** Hoosier Racing STARS or TUSA plated tires allowed.
- 15.5.** Hoosier spec tire allowed in compounds 1350 or 1600.
- 15.6.** All tires must Durometer 40 minimum before the race.

16. SAFETY EQUIPMENT

- 16.1.** Fire resistant driving suit required. Single layer minimum, double layer or more recommended.
- 16.2.** SFI/TFI approved fireproof gloves required
- 16.3.** SFI/TFI approved fireproof shoes required.
- 16.4.** Full-face helmet required. Must be SFI/FIA approved and a Snell date no older than 10 yrs.
- 16.5.** Head and neck restraint required. Recommended SFI 3.38.1
- 16.6.** Driving racing harness/restraint required, SFI 16.1, and a date no older than 2 yrs.
- 16.7.** Full containment seat required – Rule to go in effect July 1, 2024.
- 16.8.** Arms restraint optional.

17. ENGINE SPECIFICATIONS STOCK/SPEC ONLY

The intent of the stock engine is to use engines directly from a factory supplied street legal motorcycle, without any modifications whatsoever. If there is something that has not been addressed in the above specification, do not assume modifications can be made. You must request clarification from your governing body with any item that has not been directly addressed.

17.1. ALLOWABLE ENGINE PACKAGES

- GSXR/GSXS 1000 2022 or older
- Honda CBR 1000RR 2022 or older
- Yamaha YZFR1 10 2022 or older
- Kawasaki ZX 10 2022 or older

17.2. Engine Mounting

17.2.1. Engine must be front mounted in engine compartment.

17.2.2. Engine setback

17.2.2.1. The "square of the engine" (rear fins of the jugs) may not extend rearward more than 17" from the center of front spindle.

17.2.2.2. No part of the engine or transmission may extend rearward more than 21 inches from center of front spindle.

17.3. GENERAL ENGINE RULES

17.3.1. Engine parts from different year engines can be swapped between engine providing they are from the same manufacture and same cc displacement.

17.3.2. No modifications to the bottom of the engine will be allowed, all bottom end components must remain in stock configuration. Charging system optional. Battery powered ignition system only. Alternator cover allowed. Factory balancer and/or balancer shaft maybe removed.

17.3.3. Engine must be cooled by original intent. May use extra fan or oil cooler.

17.3.3.1. Electric water pumps allowed. With optional block-off plate over OEM pump opening.

17.3.4. All head components must be OEM stock. After market cylinder heads and valves will not be permitted.

17.3.5. No porting, or grinding, polishing, or changing stock configuration of intake or exhaust ports allowed.

17.3.6. No altering of pistons, rods, head components. Crank, rods and pistons must remain OEM

17.3.7. Engine must remain in its stock factory manufactured condition. Bore and stroke must remain unaltered from a factory manufactured specification. No increasing or decreasing of motor stroke in any way. No engine can be modified to be less than original stock OEM configuration specifications. Freshening of stock engine must only involve the replacement of any worn or faulty parts, with factory manufactured parts intended for use on that particular engine.

17.3.8. No auxiliary starters.

17.3.9. Engine exhaust must include muffler and exit rearward. All muffler devices must include baffles. MUFFLER MUST MEET LOCAL TRACK REGULATIONS, (IF MANDATORY)

17.3.10. Header must attach directly to head in stock exhaust port location.

17.3.11. Engine must be in production for a designated time period to determine its competitive relationship with our current motor program.

17.3.12. Any major changes to the existing engine by the manufacturer must be reviewed by the UNITED CC MODIFIED SERIES Board Officials before approval.

17.3.13. All electronic and/or computerized wheel spin and/or ignition retardation and/or acceleration limiting and/or traction control devices of any type will not be permitted.

- 17.3.14.** At NO time will there be any type of ping control devices, dial a chip controller(s), timing controls, or any modifications to the ignition control boxes, distributors, or any other part of the Ignition System. This includes any add on component or components inside or outside the cockpit of any competitor's racecar. There shall be NO driver-controlled wheel spin, timing or fuel delivery control devices in the cockpit area of any racecar.

17.4. CAMS

- 17.4.1.** Cams must be as per original equipment manufacturer (OEM) and meet OEM specifications.
- 17.4.2.** Kawasaki Racing Exhaust-Camshaft part number 49118-0729, Kawasaki Racing Intake-Camshaft part number 49118-0728, Kawasaki Cam Sprocket part number 120460034 are not permitted
- 17.4.3.** Optional cam sprockets permitted.
- 17.4.4.** Cam shafts must remain stock lift and duration and be in their original placement. (i.e., intake on intake side, and exhaust on exhaust side).

17.5. OIL SYSTEM

- 17.5.1.** Oiling system may not include a dry sump system,
- 17.5.2.** One piece billet or cut oil pans allowed.
- 17.5.3.** High volume oil pump gear allowed.
- 17.5.4.** The oil pan may be steel, or aluminum.

17.6. FUEL SYSTEM

- 17.6.1.** Engines must remain with the fuel injection or carburetors that it was originally intended to run from factory.
- 17.6.2.** Fuel injection boot must fasten directly to head in the stock intake port location.
- 17.6.3.** Aftermarket velocity stacks permitted.
- 17.6.4.** No ram air induction.
- 17.6.5.** Fuel injection casting part line must be visible upon inspection. Intake ports must remain un-altered.
- 17.6.6.** Only one fuel monitoring device can be used, but may not include modules, or devices to alter motor function.

17.7. IGNITION SYSTEM

- 17.7.1.** OEM stock ignition system only. Power commanders up to 5 USB and or TFI, may be used. Oxygen sensors or components will not be permitted. Component added to allow traction control will not be allowed. Bazzaz fuel performance devices will not be allowed.
- 17.7.2.** Wiring harness must be left exposed and visible for easy inspection.

17.8. FUEL

- 17.8.1. Any type of manufactured pumped gasoline allowed, including ethanol-based fuels such as E85 will be allowed.
- 17.8.2. No nitro/nitrous methane or Methanol/Alcohol allowed.
- 17.8.3. No nitro allowed in fuel or oil.

17.9. ENGINE TECH PROCEDURES

17.9.1. Compression Test

17.9.1.1. Fuel injection and all 4 spark plugs must be removed before checking compression.

17.9.1.2. Compression is measured after (10) consecutive revolutions of cranking.

- Minimum compression 100 psi
- Maximum 220 psi per cylinder average or 4 cylinders, no variance.
- Measure with a Snap-On motorcycle compression gauge, part # EEPV303A with adapters: EEPV304A, EEPV306a or MY261200, EEPV305A or Snap-on motorcycle compression gauge set EEPV503 with adapters: EEPV5G10L, EEPV5G12L and EEPV5G14L. Or equivalent Snap-on gauge and adapters, approved by tech personnel.

18. MISCELLANEOUS RULES

- 18.1. NO two-way communication devices.
- 18.2. One-way raceceivers from officials only. Using a one way only device.
- 18.3. SAM-COM Radio Purchased from UccMS Permitted, placed behind driver seat out of drivers reach.
- 18.4. No mirrors allowed.
- 18.5. All drivers must be minimum of fourteen (14) years of age or track policy. All drivers under 18 years of age MUST have a signed waiver by parent or guardian.

19. GENERAL REGULATIONS

- 19.1. The rules and/or regulations set forth herein are designed to provide for the orderly conduct of racing events and to establish the minimum acceptable requirements for such events. These rules shall govern the condition of all events, and, by participating in these events, all participants are deemed to have accepted and complied with these rules. NO EXPRESSED OR IMPLIED WARRANTY OF SAFETY SHALL RESULT FROM PUBLICATION OF OR COMPLIANCE WITH THESE RULES AND REGULATIONS. They are intended solely as a guide for the conduct of the sport and are in no way a guarantee against injury or death to a participant, spectator, or official. Any interpretation or deviation of these rules is left to the discretion of UNITED CC MODIFIED SERIES Officials and the decision is final. NO

EXPRESSED OR IMPLIED WARRANTY OF SAFETY SHALL RESULT FROM SUCH DEVIATION OF SPECIFICATIONS.

- 19.2.** UNITED CC MODIFIED SERIES reserves the right to reject or allow entry of any driver or car.
- 19.3.** No intoxicating spirits or controlled substances are to be consumed before or during race events by any competitor(s).
- 19.4.** Abuse or confrontation of any racetrack or UNITED CC MODIFIED SERIES official and/or use of abusive language is strictly prohibited. FAILURE TO ABIDE BY THIS RULE MAY RESULT IN SUSPENSION, LOSS OF POINTS, WINNINGS, RECORDS, AND/OR CASH FINE.
- 19.5.** Any disputes involving qualifying times, lap scoring, finishing position is under the jurisdiction of the hosting track officials. UNITED CC MODIFIED SERIES officials will address winnings, points, or rules interpretations. Any disputes or discussions of this nature are to be held with UNITED CC MODIFIED SERIES officials only.
- 19.6.** Drivers, owners, and/or crew shall have no claims or actions of any kind against or cause of action for damages of any kind, expenses, or otherwise against UNITED CC MODIFIED SERIES, any track owner, promoter, or official by reason of disqualification or damage to either car, driver, or both. This regulation shall be deemed a covenant not to sue made by each driver, owner, and/or crewmember to UNITED CC MODIFIED SERIES, any track owner, promoter, or official with respect to any alleged act or omission or agreement by any of him or her.
- 19.7.** UNITED CC MODIFIED SERIES or track officials may inspect any car any time for safety, mechanical, or rules compliance may inspect any car.
- 19.8.** ANY RULES OR REGULATIONS NOT COVERED IN THIS BOOKLET WILL BE DETERMINED ON A TIMELY BASIS BY UNITED CC MODIFIED SERIES AND THE DECISION IS FINAL.
- 19.9.** MOTORSPORTS RACING IS A DANGEROUS SPORT AND MAY RESULT IN INJURY, BODILY HARM, OR DEATH.
- 19.10.** The race director shall be empowered to permit reasonable and appropriate deviation from any of the specifications herein or impose any further restrictions that in his opinion do not alter the minimum acceptable requirements. No expressed or implied warranty of safety shall result from such alteration of specifications. Any interpretation or deviation of these rules is left to the discretion of the United cc Modified Series officials and their decisions are final.
- 19.11.** Points go to the driver only. No exceptions.
- 19.12.** In cases where the finish of the race is too close to call (in real time) by way of transponder(s), the track officials may use photo(s), video or electronic scoring, if available, to aid in determining the winner.
- 19.13.** United cc Modified Series officials have final say on all official calls and rules.
- 19.14.** All drivers must attend United cc Modified Series Driver's Meeting.

20. GENERAL GUIDELINES FOR CONDUCT PERTAINING TO RULES INFRACTIONS

- 20.1.** Anyone found to be out of compliance with the rules of driver and car overall weight requirements, wheelbase, illegal suspension, weight, safety, etc. (as per current rule book for the UNITED CC MODIFIED SERIES) will be assessed the following penalties:
- 20.1.1. FIRST OFFENSE:** Forfeit of points and monies for the race program of record and warning to have the violation corrected before being allowed to compete at the next event.
- 20.1.2. SECOND OFFENSE:** Driver will incur the same fines and penalties as first offense but will subsequently earn an additional race suspension.
- 20.1.3. THIRD and SUBSEQUENT OFFENSES:** Driver will incur same fines and earn an additional 2 race suspension and forfeit all points earned to date.
- 20.2. REFUSAL TO SUBMIT TO TECH PROCEDURES**
- 20.2.1.** Any driver or car owner that refuses to be tech'd by the UNITED CC MODIFIED SERIES will result in a maximum suspension and loss of points to date. The length of the suspension will be solely at the discretion of the UNITED CC MODIFIED SERIES board members and will be voted upon by the entire board after a meeting is convened to discuss the matter. All decisions are binding and final; no appeals or changes may be made after the issue is settled. The meeting shall not be conducted on the night of the program in question.
- 20.2.2.** Race cancellations will not be counted towards the suspension period earned by the offending driver.

21. RACERS' CODE OF CONDUCT

- 21.1.** All drivers entering a UccMS series event shall be subject to discipline for any violation of the rules and regulations: violation of the racers' code of conduct, or the failure to obey the directives and decisions of the UccMS Officials.
- 21.2.** The drivers shall be responsible, at all times, for the behavior of the owner of the car and all pit crew and discipline may be imposed upon the driver for any car owner's or pit crew member's violation of the rules and regulations; violation of the Racer's Code of Conduct; or the failure to obey the directives and decisions of the United cc Modified Series Officials. However, United cc Modified Series may also impose discipline upon the offending car owner or pit crew member as United cc Modified Series Officials deem appropriate in their sole discretion.
- 21.3.** All drivers, car owners and pit crew members shall at all times conduct themselves in a manner that reflects favorably upon the sport and the United cc Modified Series Any failure to adhere to this rule may result in the imposition of discipline, in the sole discretion of the United CC Modified Series
- 21.4.** No driver, car owner or pit crew member shall before, during, or after the event (as well as support classes) possess, use, consume or distribute any drug, narcotic or controlled substance which is illegal under federal, state or local law

prevailing at the speedway. The United cc Modified Series has a zero tolerance for illegal drugs, narcotics, and controlled substances. Any violation of this policy shall be grounds for immediate disqualification from the event, expulsion from the speedway grounds, criminal prosecution and imposition of any other discipline (including a lifetime ban) deemed appropriate by the United cc Modified Series Officials. Any person suspected of possession, use, consumption, or distribution shall submit to a medical examination (which may include blood and/or urine testing) within 24 hours, with the cost of same to be paid by the person suspected and with the written results to be provided directly to United CC Modified Series. Any substance suspected to be an illegal drug, narcotic, or controlled substance shall be confiscated by United cc Modified Series Officials and/or speedway security and/or law enforcement officers and may be subject to testing with the cost of same to be paid by the person suspected and with the written results provided directed to United cc Modified Series

21.5. No driver, car owner or pit crew member shall possess, use, consume or distribute any alcoholic beverage on the speedway grounds before the event or while the evening's program (including all support classes) is still in progress unless the person is in a spectator area where consumption of alcoholic beverages is permitted by the speedway and the United cc Modified Series portion of the program has been completed.

21.6. No driver, car owner or pit crew member shall be permitted to enter or remain in the pits or infield while under the influence of alcohol or any illegal drug, narcotic, or controlled substance. Any person suspected of being under the influence of alcohol or any illegal drug, narcotic, or controlled substance shall submit to a medical examination (which may include blood and/or urine testing) within 24 hours, with the cost of the same to be paid by the person suspected and with the written results to be provided directed to the United cc Modified Series. Any person refusing to submit to a medical examination shall be presumed to have possessed, used, consumes, or distributed a drug, narcotic or controlled substance, or alcohol, and shall be subject to discipline, in the sole discretion of the United cc Modified Series

21.7. Any person taking part in discourteous conduct or causing a disturbance is subject to discipline. Persons leaving their pit area to go to another pit area or to any other location to cause a disturbance are subject to discipline. If any physical contact occurs, including but not limited to fighting, pushing or shoving, the offender is subject to discipline which shall include the loss of accumulated points and a fine and suspension, the amount and duration of which shall be determined by United cc Modified Series Officials in their sole discretion. Repeat offenders shall be subject to progressive discipline (which may include a lifetime ban). The United cc Modified Series disapproves of this sort of behavior because it is detrimental to the sport and the presentation of a professionally staged entertainment program suitable for the entire family.

- 21.8.** It is the policy of United cc Modified Series to provide good, clean, competitive racing. Any driver, in the opinion of United cc Modified Series Officials, charged with rough driving (overly aggressive driving) will be subject to discipline, which shall include a fine, forfeiture of points, and suspension. Repeat offenders shall be subject to progressive discipline (which may include a lifetime ban). This rule against rough driving applies to both on-track incidents and those which occur in the pits. The United cc Modified Series strongly disapproves of rough driving because it presents a safety hazard for drivers, spectators, and others; because it is detrimental to the sport; and because it interferes with the presentation of a professionally staged entertainment program suitable for the entire family.
- 21.9.** No driver or other person affiliated with the car (i.e., owner, pit crew member) shall subject the United cc Modified Series Officials, scorers, or speedway officials to verbal (improper/obscene/profane language) or physical abuse at any time. Offenders shall be subject to discipline, which shall include a fine, forfeiture of points, and suspension, and repeat offenders shall be subject to progressive discipline. The United cc Modified Series disapproves of this sort of behavior because it is detrimental to the sport and the presentation of a professionally staged entertainment program for the entire family.
- 21.10.** No driver shall engage in any unsportsmanlike conduct. United cc Modified Series Officials have the sole discretion to determine what constitutes unsportsmanlike conduct.

22. MEDIA RELATIONS

- 22.1.** The United cc Modified Series recognizes and endorses the efforts of the racing media to promote modified lite racing and other forms of motorsports. Any driver refusing to participate in an on-track interview at the end of the event, any post-race interview arranged by United cc Modified Series or in any post-race press conference shall be subject to discipline, including but not limited to imposition of a fine that shall be equal to or greater than the driver's winnings.

23. TECHNICAL INSPECTIONS

- 23.1. PRIOR INSPECTIONS** The fact that a car was inspected and determined to be legal or safe on any prior occasion shall not govern. Cars must be legal and safe at all times. Cars deemed to be illegal or unsafe shall not be allowed to compete in the event and the driver may be subject to discipline. The United cc Modified Series Officials make no warranty or representation of the legality or safety of cars allowed to compete in the event.
- 23.2. POST-RACE INSPECTIONS** If any illegality is detected in any post-race inspection, the car will be disqualified, relegated to last place in the official order of finish for the race in which the disqualification occurred and the driver may be subject to discipline, which may include but is not limited to forfeiture of purse and/or points.
- 23.3. WEIGH-IN PROCEDURE** The car must approach the scales at a safe speed, ease onto the scales, come to a complete stop, and let the engine idle. If the car is not

positioned properly, it shall ease off the scales and repeat the procedure. The driver shall refrain from excessive motion while the car is on the scales and shall not rock or bounce the car. The driver shall not rev the motor. When instructed, the car shall ease off the scales. Failure to comply with any portion of this procedure shall be deemed to be unsportsmanlike conduct and the driver may be subject to discipline which may include disqualification without right of protest or appeal.

- 23.4. CAR DETERMINED LIGHT** If a car is determined to be too light after the race is over the car shall be reweighed. The United cc Modified Series Officials, in their sole discretion, shall determine the best course of action for reweighing. Locations of the scales, proximity of the line of cars, are but two factors in that determination. The United cc Modified Series Officials may simply back the car back up onto the scales and reweigh. The car shall repeat the weigh-in procedure. If the car is determined to be too light again, it will be disqualified from that race and relegated to last place in the official order of finish, all without right of protest or appeal. If the car makes the minimum weight the second time it is weighed, it will be deemed to be legal. No car will be weighed more than two (2) times. If the driver goes to his pit area or onto the track, it will be presumed that the car is too light and it will be disqualified from that race and relegated to last place in the official order of finish, all without right of protest or appeal, and the driver may be subject to discipline.
- 23.5. DRIVER'S RESPONSIBILITY** It is the driver's responsibility to be sure that the car meets the minimum weight at all times. The driver may request that the car be weighed at any time before or during the program, so long as the request does not interfere with the orderly presentation of the program.
- 23.6. NO TOLERANCE** The United cc Modified Series does not allow for any tolerances for fuel burn-off or any other reason.
- 23.7. SCALES ARE OFFICIAL** All scales used by United cc Modified Series are considered to be the official scales for that racing event only. The scales might not be calibrated or certified to be considered official.
- 23.8. ALL DECISIONS FINAL** The decisions of the United cc Modified Series Officials concerning compliance with the weight requirements and procedures shall be final and shall not be subject to protest or litigation.

24. FORMS OF DISCIPLINE

- 24.1.** United cc Modified Series Officials may impose any of the following forms of discipline, singly or cumulatively:
- 24.1.1.** Disqualification from the event
 - 24.1.2.** Forfeiture of points for the event or the season to date
 - 24.1.3.** Forfeiture of purse money or contingency money
 - 24.1.4.** Forfeiture of point/money, if any
 - 24.1.5.** Imposition of a fine
 - 24.1.6.** Suspension from one or more future events
 - 24.1.7.** Lifetime ban from all United cc Modified Series events.

- 24.2. PROGRESSIVE DISCIPLINE** The United cc Modified Series shall keep a record of all discipline imposed. Persons subject to progressive discipline shall suffer a greater penalty for the second and each subsequent offense. For example, if a driver is fined \$100 for the first offense, the second offense may result in a fine of \$200 and the third offense may result in a fine of \$300. Progressive discipline; however, shall not carry over to the following season.
- 24.3. FINES** All fines imposed by the United cc Modified Series before the pay-off is made shall be withheld from the purse or contingency monies the driver is eligible to receive for the event. If the purse or contingency monies due the driver are not sufficient to satisfy the fine, the fine will carry forward to subsequent United cc Modified Series events. If the fine is imposed after the pay-off is completed for that event, it will carry forward to subsequent United cc Modified Series events. A driver must pay all outstanding fines to be allowed to enter any subsequent United cc Modified Series events. If an owner/driver does not pay a fine imposed, the owner/driver's car cannot compete in a subsequent United cc Modified Series event with another driver until the fine is paid. A car owner must pay all fines before the car may be driven in any subsequent United cc Modified Series event. Any fines remaining unpaid at the end of the season shall be withheld from the driver's point money, if any is due the owner/driver. If the point money is insufficient to pay the outstanding fine or if the driver is not eligible for any point money, the fine shall carry over from season to season until it is fully paid.
- 24.4. SUSPENSIONS** All suspensions must be fully served. Cancelled events do not count against the suspension. For example, if a driver is suspended for two (2) events and the next event is cancelled due to inclement weather, the suspension continues in effect until fully served. Any suspension imposed shall carry over to the following season until fully served. For example, if a driver is given a three-race suspension but only two events remain on the schedule, the suspension will still be in effect at the first event of the following season.
- 24.5. FINALITY OF DECISION** The decisions of the United cc Modified Series Officials regarding discipline shall not be subject to protest or litigation.
- 24.6. NOT LAW ENFORCEMENT** While the United cc Modified Series has the right to impose discipline for any misconduct that is in violation of any law (such as assault, terroristic threats, public intoxication, or illegal drug use), the United cc Modified Series Officials are not responsible for law enforcement or investigation. Rather, investigation and prosecution shall be the responsibility of law enforcement officials and/or speedway security. United cc Modified Series Officials shall cooperate whenever practicable, but are not bound by any decision of law enforcement and/or security to the undertake or to decline an investigation or prosecution.

25. PROTEST

- 25.1. SPOKESMAN** The driver shall be the sole spokesman for the team and the car owner.

- 25.2. RIGHT TO PROTEST** Any affected driver may protest any violation of the rules (including car specifications and weight requirements) unless the rules expressly preclude the filing of a protest or appeal.
- 25.3. VISIBLE PROTESTS** may be made concerning visible violations of rules or specifications. A visible protest situation is any time a tool or mechanical device is not needed by a United cc Modified Series Official to determine the car's compliance with the rule.
- 25.4. TECHNICAL PROTESTS (Top 5 finishers only protestor/protestee)** Technical protests must be filed with the United cc Modified Series Race Director and must be accompanied by a \$500 fee, paid in cash before investigation. Failure to pay the protest fee, in cash, shall be deemed a waiver of the right to protest and shall preclude any subsequent appeal or litigation. A technical protest situation is any protest which requires any tool or mechanical device (including scales) for a United cc Modified Series Officials to determine a car's rule compliance. For the purpose of a subsequent appeal, all measurements by United cc Modified Series Officials are presumed to be correct, absent a showing by the driver of a mistake or prejudice. If the protested car is found to be illegal, it shall be the burden of the driver to establish legality in any subsequent appeal or litigation. If the protested car is found to be illegal, the protest fee is refunded to the protester, less an administrative fee of \$250.00, which shall be retained by the United CC Modified Series. If the car is found to be legal, the fee is retained by the United CC Modified Series, with \$250.00 going to the United cc Modified Series and \$250.00 going to the protested car. Cars that are found to be illegal will forfeit all points earned for the race in questions and the driver will also forfeit any earnings due for that race. The United cc Modified Series shall not be responsible for any damage caused by the inspection.
- 25.5. RACE RESULTS PROTESTS** Any affected driver may protest race results within 10 minutes after the race. A recheck of scoring will then be made, if necessary, and, thereafter, the results will be considered final.
- 25.6. HOLDING THE PURSE** In the event of a protest, the speedway may, with the advice and consent of the United CC Modified Series, delay purse distribution until the matter is ultimately decided by the appeal board. The speedway can, at its discretion and with the advice and consent of the United CC Modified Series, distribute that portion of the purse to drivers whose finishing positions will not be affected by the protest or any subsequent appeal.
- 25.7. RIGHT TO REFUSE PROTEST** The United cc Modified Series reserves the right to refuse any protest if the protest is deemed unnecessary and/or is deemed to have been used for purposes of harassment.

